



## NEW: Mechanical Suspension ECO CARGO VB for 5.5t axle loads - available from March 1, 2016

For axle loads 5.5t with disc or drum brake BPW offers previously air suspensions in full range. Those running gears are used successfully in the long-distance transport, i.e. high volume transporters.

With the new mechanical suspension, ECO Cargo VB for 5.5t axle loads offers BPW now a reliable and robust solution for many more applications in construction, landscaping and municipal services.

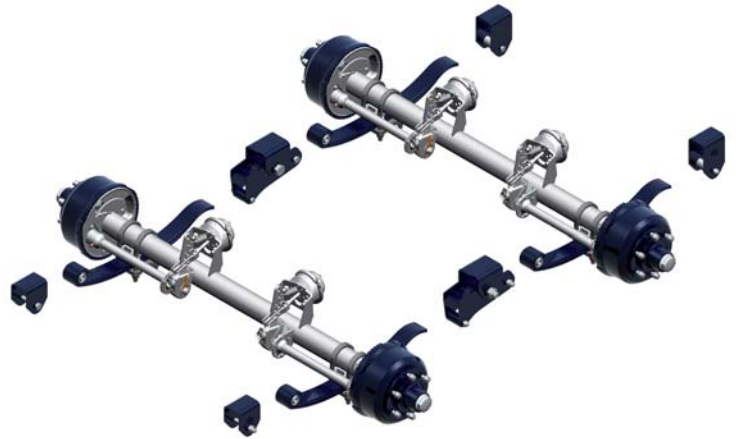

The new ECO CARGO VB can be supplied in single parts or in preassembled units for specific customer's requirements.

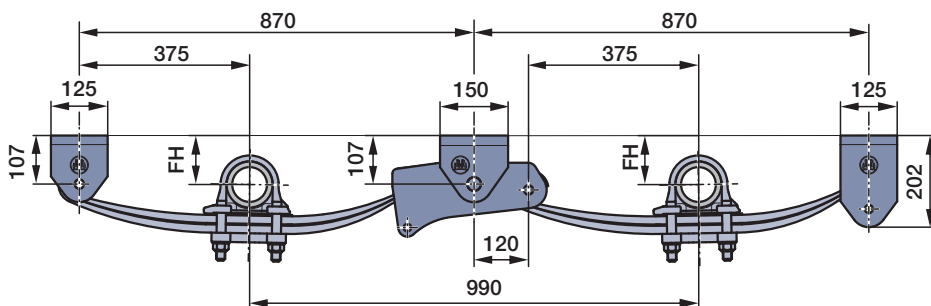

The benefits of ECO CARGO VB are:

- flexibly usable with top- or bottom-mounted suspension
- short installation time with pre-assembled parabolic springs / brake cylinder
- low-maintenance equalizer bearing thanks to the steel - rubber bushing
- comprehensive corrosion protection (KTL<sub>Zn</sub>)
- available with disc or drum brake
- on request with uncoated hanger brackets
- from single source with BPW quality



Type	Axle load (kg)	Wheel base (mm)	Leaf spring width (mm)	Leaf spring thickness (mm)	Suspension type	Ride height (FH)	
						loaded (mm)	unloaded (mm)
 VB	5500	990	80	2x18	single axle suspension	254	275
					tandem-axle suspension	256	277
 VBT					single axle suspension	81	102
					tandem-axle suspension	83	104

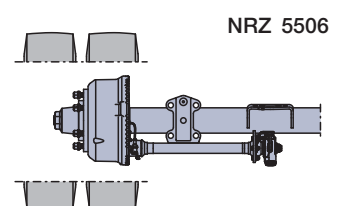
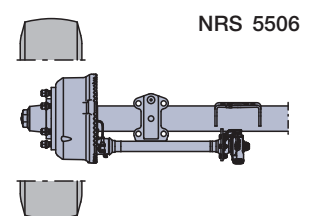
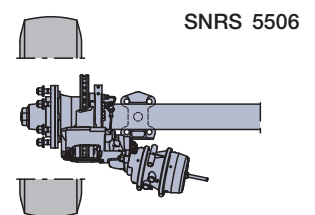

For further information, please contact your BPW partner.